

LINDY®

CONNECTION PERFECTION

CAT 5e/6 Infra-Red Extender

User Manual

English



LINDY No. 38007



www.lindy.com

User Manual

Introduction

Thank you for purchasing the LINDY Infra-Red Extender. It's the perfect device for controlling equipment over long distances. Using the included IR receiver and low cost CAT5e/6 cable you can control up to 5 items at the same time using your existing remote controls. You can also control 3 devices from up to 250m away.

Package Contents

- IR Extender Local Unit
- IR Receiver Remote Unit
- 1 x IR Receiver Eye, approx 1.9m (large eye)
- 5 x IR Transmitter Cables, approx 2m (small eye)
- 5V DC 1A PSU
- This Manual

Specifications

- 5 x transmitter ports (3 on the remote unit & 2 on the local unit)
- Control devices up to 250m away
- Use existing remote controls
- Aluminium enclosures
- IR Receiver frequency: 20~60KHz
- Dimensions: 50 x 62 x 22mm (WxDxH)

Connectors

Front

1. IR Out 1, 2 & 3 (Remote Unit): Connect the included IR transmitter cables to these ports
2. IR In (Local Unit): Connect the included IR receiver eye to this port
3. IR Out 1 & 2 (Local unit): Connect the included IR transmitter cables to these ports

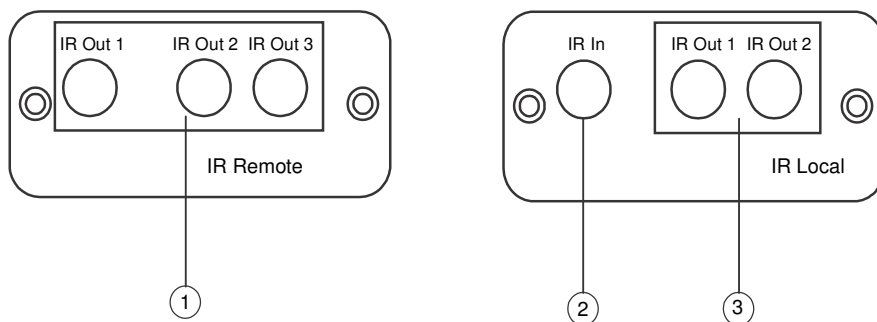

Rear

1. Use up to 250m CAT5e/6 cable to connect your Local and remote units.
-

User Manual

2. Connect the included 5V DC power supply to either the local or remote unit

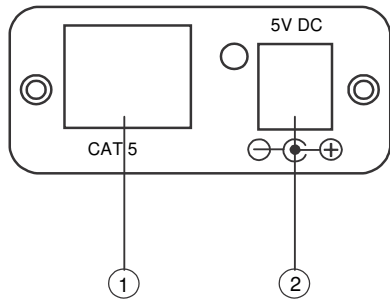

Typical Set-up

Note: The IR receiver's maximum recommended distance is 7m from the eye to your remote control

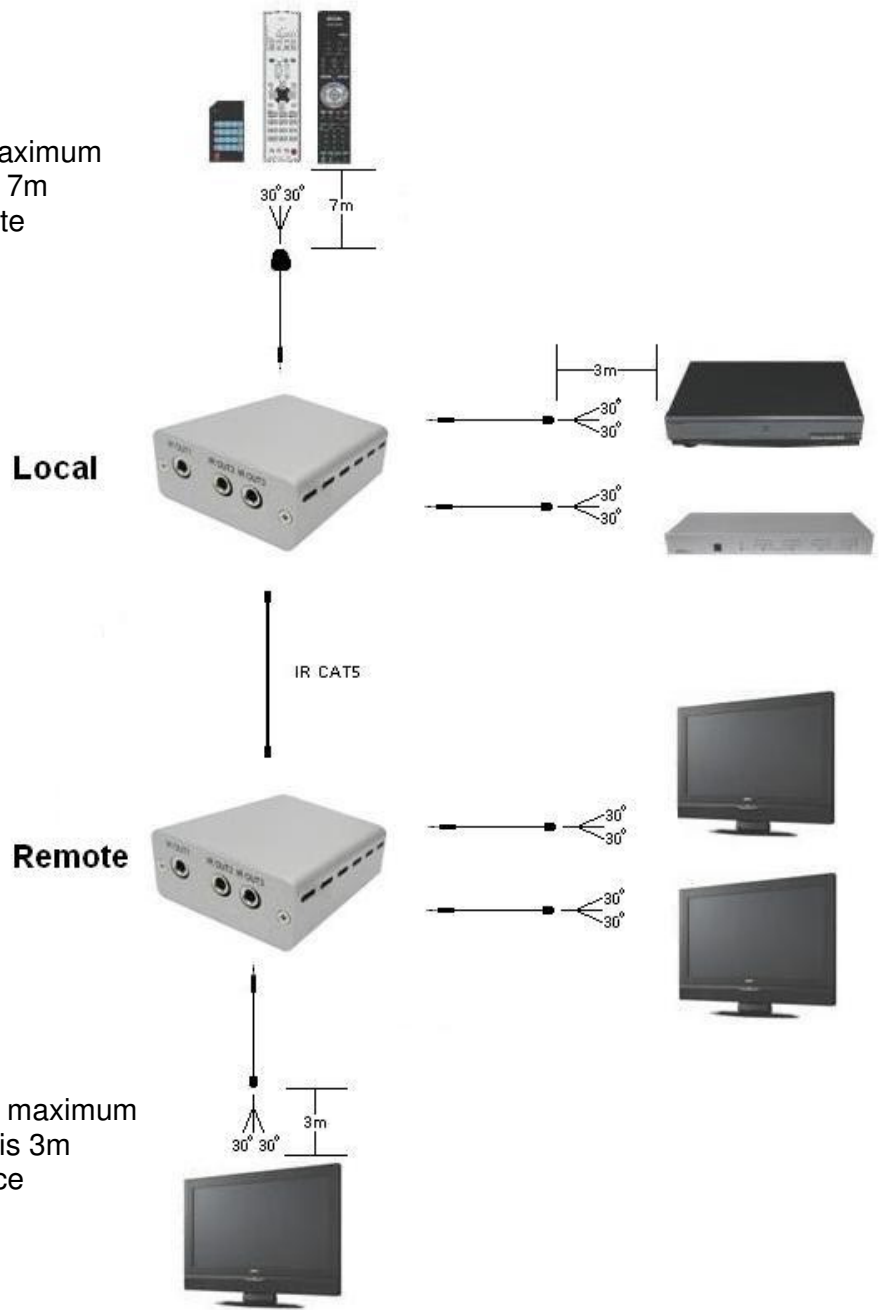

CE/FCC/Recycling Information

CE Certification

This equipment complies with the requirements relating to electromagnetic compatibility, EN55022/EN55024 class B for IEC/EN61000-4-2/3 the essential protection requirement of Council Directive 89/336/EEC on the approximation of the laws of the Member States relating to electromagnetic compatibility.

FCC Certification

This equipment has been tested and found to comply with the limits for a Class B digital device, pursuant to part 15 of the FCC Rules. These limits are designed to provide reasonable protection against harmful interference in a residential installation.

This equipment generates, uses, and can radiate radio frequency energy and, if not installed and used in accordance with the instructions, may cause harmful interference to radio communications. However, there is no guarantee that interference will not occur in a particular installation. If this equipment does cause harmful interference to radio or television reception, which can be determined by turning the equipment off and on, the user is encouraged to try to correct the interference by one or more of the following measures:

- Reorient or relocate the receiving antenna
- Increase the separation between the equipment and receiver
- Connect the equipment into an outlet on a circuit different from that to which the receiver is connected
- Consult the dealer or an experienced technician for help

You are cautioned that changes or modification not expressly approved by the party responsible for compliance could void your authority to operate the equipment.

This device complies with part 15 of the FCC Rules.

Operation is subject to the following two conditions:

1. This device may not cause harmful interference, and
2. This device must accept any interference received, including interference that may cause undesired operation.



WEEE (Waste of Electrical and Electronic Equipment), Recycling of Electronic Products

United Kingdom

In 2006 the European Union introduced regulations (WEEE) for the collection and recycling of all waste electrical and electronic equipment. It is no longer allowable to simply throw away electrical and electronic equipment. Instead, these products must enter the recycling process.

Each individual EU member state has implemented the WEEE regulations into national law in slightly different ways. Please follow your national law when you want to dispose of any electrical or electronic products. More details can be obtained from your national WEEE recycling agency.

Germany

Die Europäische Union hat mit der WEEE Richtlinie umfassende Regelungen für die Verschrottung und das Recycling von Elektro- und Elektronikprodukten geschaffen. Diese wurden von der Bundesregierung im Elektro- und Elektronikgerätegesetz – ElektroG in deutsches Recht umgesetzt. Dieses Gesetz verbietet vom 24. März 2006 an das Entsorgen von entsprechenden, auch alten, Elektro- und Elektronikgeräten über die Hausmülltonne! Diese Geräte müssen den lokalen Sammelsystemen bzw. örtlichen Sammelstellen zugeführt werden! Dort werden sie kostenlos entgegen genommen. Die Kosten für den weiteren Recyclingprozess übernimmt die Gesamtheit der Gerätehersteller.

France

En 2006, l'union Européenne a introduit la nouvelle réglementation (DEEE) pour le recyclage de tout équipement électrique et électronique.

Chaque État membre de l' Union Européenne a mis en application la nouvelle réglementation DEEE de manières légèrement différentes. Veuillez suivre le décret d'application correspondant à l'élimination des déchets électriques ou électroniques de votre pays.

Italy

Nel 2006 l'unione europea ha introdotto regolamentazioni (WEEE) per la raccolta e il riciclo di apparecchi elettrici ed elettronici. Non è più consentito semplicemente gettare queste apparecchiature, devono essere riciclate. Ogni stato membro dell' EU ha tramutato le direttive WEEE in leggi statali in varie misure. Fare riferimento alle leggi del proprio Stato quando si dispone di un apparecchio elettrico o elettronico.

Per ulteriori dettagli fare riferimento alla direttiva WEEE sul riciclaggio del proprio Stato

2nd Edition November 2009



www.lindy.com

No. 38007